

HEICO-LOCK® WHEEL NUT

ASSEMBLY INSTRUCTIONS



Contact: **HEICO Befestigungstechnik GmbH**
Ensestraße 1-9
D-59469 Ense-Niederense
Germany

Telefon: +49 (0) 2938/805-0
Telefax: +49 (0) 2938/805-198
E-Mail: mail@heico-group.com
Web: www.heico-group.com

SCOPE OF APPLICATION HEICO-LOCK® WHEEL NUTS

HEICO-LOCK® Wheel Nuts can be used on steel rims on the following vehicle classes (according to 2007/46/EG annex II):

M2; M3; N2; N3; O3; O4; R3; R4; S2; T1;T2; T3; T4; T5

DESIGN OF THE HEICO-LOCK® WHEEL NUT

The HEICO-LOCK® Wheel Nut is supplied pre-assembled. The nut and the HEICO-LOCK® Wedge Lock Washers are combined in a captive and rotary way, ensuring the HEICO-LOCK® Wedge Lock Washers and the nut are fixed permanently in the correct position.

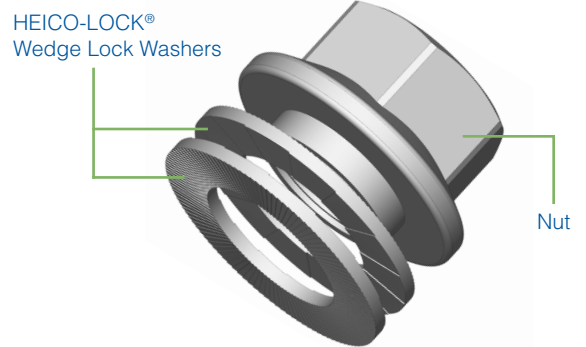

HEICO-LOCK® FUNCTIONAL PRINCIPLE

An important feature of HEICO-LOCK® Wedge Lock Washers, setting them apart from other systems that are available, is the securing of the bolt fastening using preload force rather than friction.

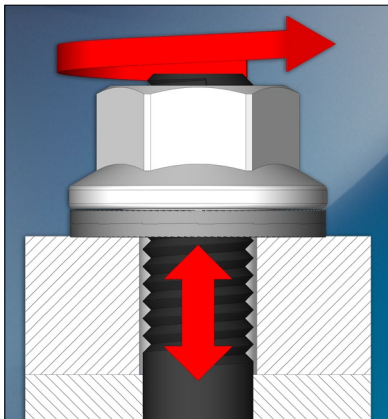

- Wedge-shaped cams on the inside of the lock washers, radial teeth on the outside
- Interlocking embedding of the radial teeth with the respective mating surface (when tightening the bolted joint)
- System movement only possible between the inner wedge shaped cams. Movement across these wedge shaped surfaces effectively self locks the bolt.
- Increase in clamping force

HEICO-LOCK® PRODUCT OVERVIEW

| HEICO-LOCK® Wheel Nut | Thread | Key Width [mm] | Outer diameter [mm] | Height [mm] | Assembly Torque [Nm] |
|-----------------------|------------|----------------|---------------------|-------------|----------------------|
| HLM-20x1.5 | M20x1.5 | 30 | 42,8 | 24,8 - 1,6 | 450 - 500 |
| HLM-22x1.5 | M22x1.5 | 32 | 46,0 | 27,25 - 1,8 | 600 - 650 |
| HLM-7/8"BSF | 7/8"-11BSF | 32 | 46,0 | 27,25 - 1,6 | 550 - 600 |

TECHNICAL DATA

| | |
|-----------------------|--|
| Surface coating: | zinc flake coated (fIZnnc) |
| Corrosion resistance: | 600 h according to ISO 9227 (NSS-test) |
| Lubrication: | pre-lubricated |
| Property class: | 10 |

INSTALLATION GUIDELINE

I) Assembly preparation

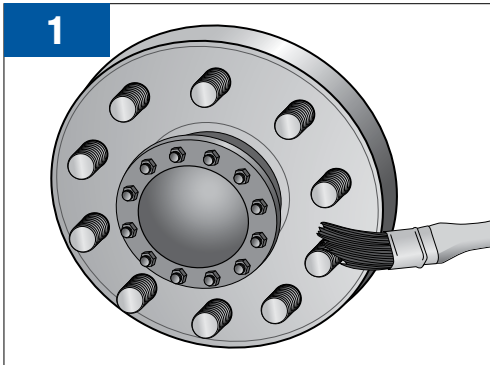

- 1) Rust and dirt have to be removed from the wheel hub, the inner hole of the wheel rim and also the wheel studs, wheel nuts and their contact surfaces before the wheel rim is attached to the wheel hub. Rusty and damaged wheel studs and wheel nuts have to be replaced.

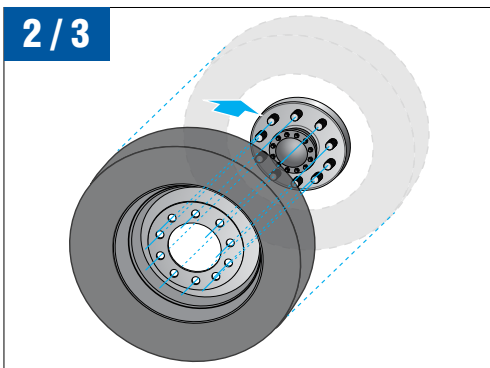

- 2) Fit the wheel rim to the wheel hub.
Caution: Do not damage the wheel studs!
- 3) Push the wheel rim to the contact surface of the wheel hub.
Caution: Do not use the HEICO-LOCK® Wheel Nuts to press the wheel rim against the wheel hub during pre-assembly!

II) HEICO-LOCK® Wheel Nut assembly

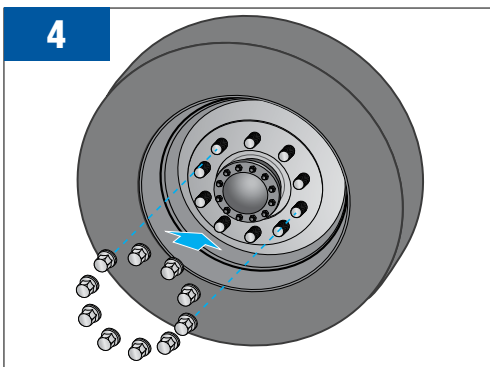

- 4) Screw the HEICO-LOCK® Wheel Nuts on all wheel studs hand-tight (max. 20 Nm).

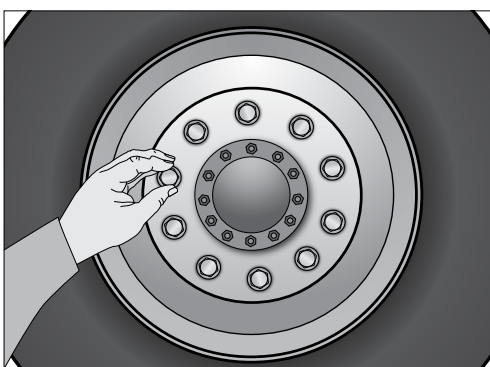

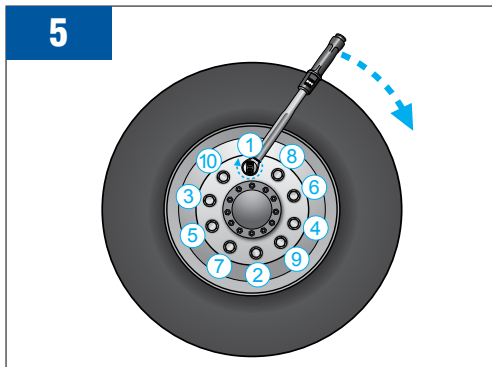

- 5) Tighten the HEICO-LOCK® Wheel Nuts with the recommended assembly torque (see table on page 2) using a calibrated hand-held signalling torque wrench following a star-pattern procedure.

III) HEICO-LOCK® Wheel Nut disassembly

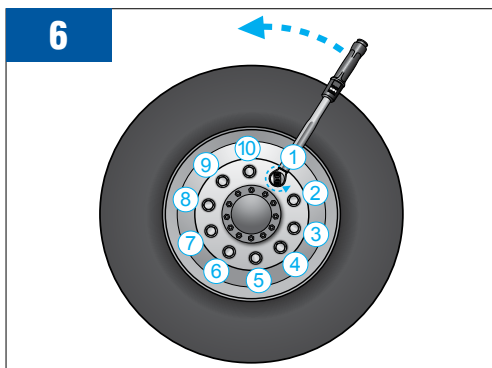

- 6) Untighten the HEICO-LOCK® Wheel Nuts by using a hand-held wrench.

GENERAL INSTALLATION NOTES

- Cleaning and lubrication of the wheel hub and the hub centering can facilitate the wheel assembly.
- HEICO-LOCK® Wheel Nuts are pre-lubricated and do not need any additional lubrication for the first assembly. In case of re-use, it is recommended to lubricate the contact surface between the wheel nut and the wheel rim as well as on the thread.
- The use of impact wrenches can lead to a significant exceedance of the permissible tightening torque so that a safe and reliable assembly cannot be guaranteed. Impact wrenches should only be used for pre-assembly with reduced torque, see installation guideline step 4) (**Caution:** Do not use the HEICO-LOCK® Wheel Nuts to press the wheel rim against the wheel hub during pre-assembly).
- For operational safety of the entire vehicle, it is highly recommended to use a calibrated, hand-held torque wrench for the wheel nut assembly.
- HEICO-LOCK® Wheel Nuts reliably prevent the wheel connection for self-loosening caused by self-rotating. However, even when precisely following all installation guideline steps, a reduction of preload force due to settlement can occur. Therefore, for operational safety and quality monitoring, it is highly recommended to retighten the HEICO-LOCK® Wheel Nuts with the recommended torque value and a calibrated hand-held torque wrench after the first kilometres in operation.

HEICO Befestigungstechnik GmbH

Ensestraße 1-9
D-59469 Ense-Niederense

Tel.: +49 (0) 29 38/ 805 -0
Fax: +49 (0) 29 38/ 805 -198

contact@heico-group.com
www.heico-group.com